



**FRESENIUS  
MEDICAL CARE**

***bi*bag<sup>®</sup> V2.0**

# **Technician's Manual**

Part Number 490188 Rev. G

## **bibag<sup>®</sup> V2.0 Technician's Manual**

© Copyright 2012 – 2016 Fresenius Medical Care, Inc.—All Rights Reserved

*This document contains proprietary and confidential information of Fresenius USA, Inc. d/b/a Fresenius Medical Care North America and its affiliates (“Fresenius Medical Care”). The contents of this document may not be disclosed to third parties, copied, or duplicated in any form, in whole or in part, without the prior written permission of Fresenius Medical Care.*

*Fresenius Medical Care, the triangle logo, 2008, and bibag are trademarks of Fresenius Medical Care Holdings, Inc., and/or its affiliated companies. All other trademarks are the property of their respective owners.*

*Any questions, contact Technical Support at 800-227-2572*

# **bi*bag* V2.0 Technician's Manual**

## **TABLE OF CONTENTS**

bi <i>bag</i> Details .....	2
General Warnings .....	3
Hydraulic Flow Diagram .....	4
Hydraulic Component Descriptions.....	5
Hydraulic Operation.....	7
Electronic Description .....	9
Electronic Block Diagram.....	11
Calibrations .....	12
Annual Maintenance .....	14
Debug Screens .....	15
Troubleshooting .....	28
Spare Parts .....	29

## bibag Details

The *bibag* connector is a hardware option that allows the usage of a dry bicarbonate powder to generate dialysate solution for the 2008<sup>®</sup>T and the 2008K@home<sup>™</sup> hemodialysis machines. The *bibag* disposable is a bag filled with dry bicarbonate powder with special inlet and outlet ports. Underneath the *bibag* door, the *bibag* hangs on two nozzles, which allow for the entry of purified water and the exit of bicarbonate concentrate solution. A door handle locks the *bibag* door in place over the *bibag* disposable.

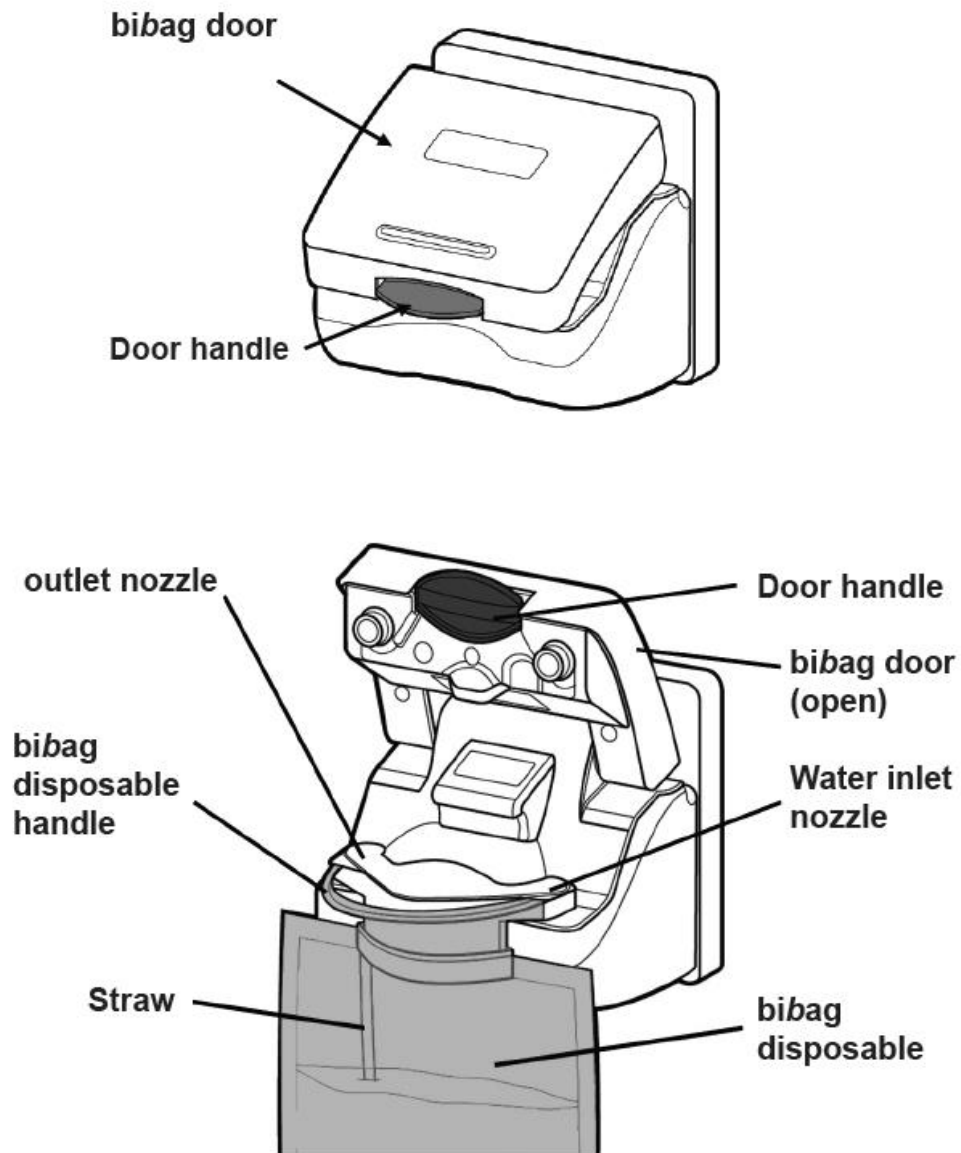

Figure 1 – *bibag* connector: door closed and *bibag* disposable inserted with door open

## General Warnings



---

**Warning:** The concentrate displayed on the screen must match the labels on the acid container. Make certain there is enough concentrate in the containers to complete the treatment.

---

**Warning:** The specific concentrate, sodium, and bicarbonate settings must be prescribed by a physician.

---

**Warning:** Acid and basic bicarbonate hemodialysis concentrate must be diluted (mixed with purified water as specified in the AAMI standards for water for dialysis) immediately prior to application only.

---

**Warning:** Use aseptic technique.

---

**Warning:** Always verify the conductivity and approximate pH of the dialysate solution through independent means before initiating dialysis. Verify that the pH is normal and that the conductivity is reasonably close to the theoretical value. If it is not, do not initiate dialysis.

---



**Warning:** Replace a leaking *bi*bag disposable immediately. Spills can cause damage to carpeting and other surfaces. To contain such spills, the machine should be on a spill-tolerant surface. Spills can cause slips and falls; clean up spills immediately.

---



**Caution:** Only the bags manufactured by Fresenius Medical Care may be used in the *bi*bag connector.

---



**Note:** When the *bi*bag connector is installed, the online pressure holding test becomes mandatory. For more information, see the Online Pressure Holding Test section of the 2008<sup>®</sup> *T Hemodialysis Machine Operator's Manual* P/N 490122 or the 2008K@home<sup>™</sup> *Hemodialysis Machine Operator's Manual* P/N 490180.

---

# Hydraulic Flow Diagram

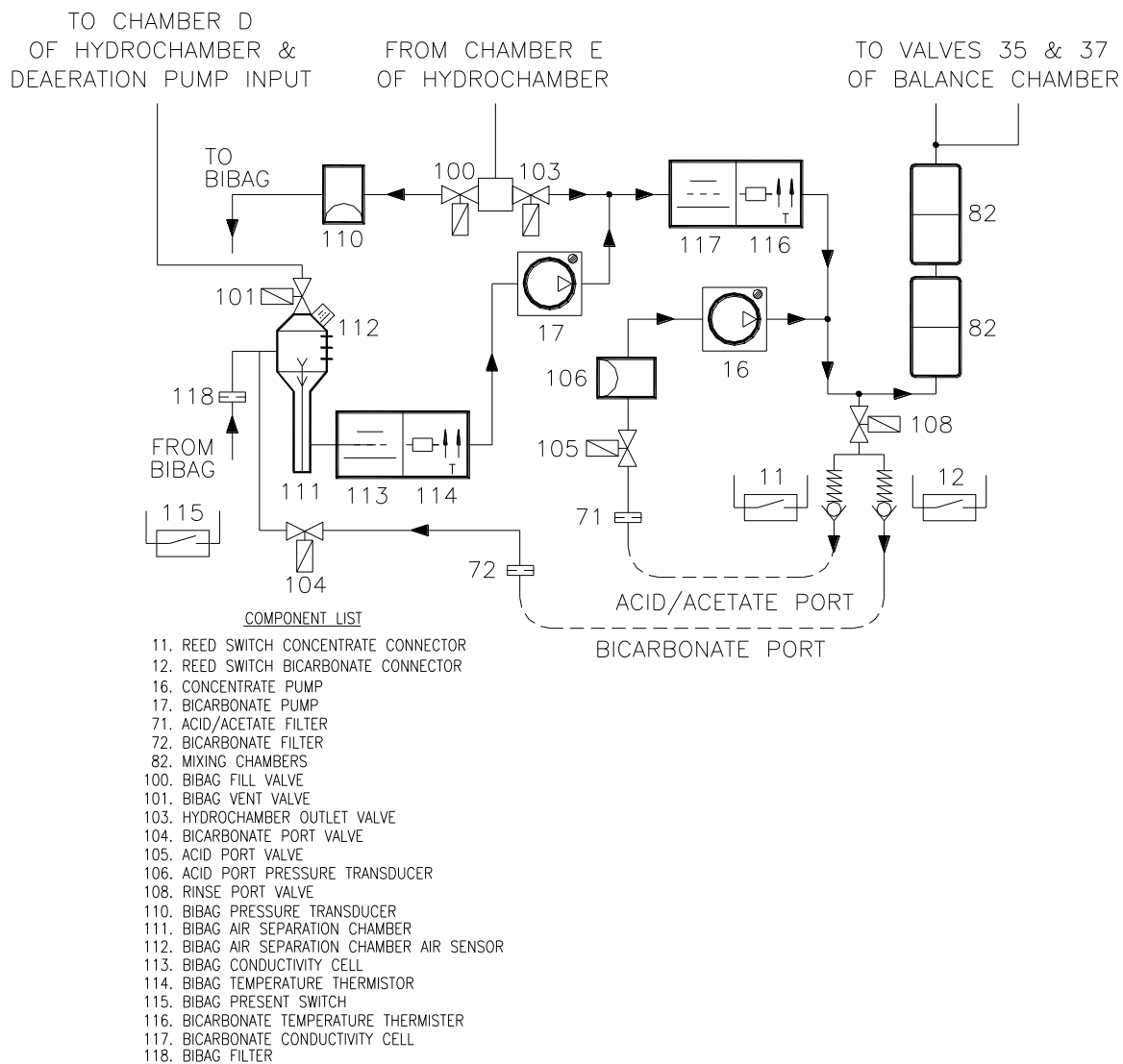

Figure 2

# Hydraulic Component Descriptions

## **100 – bibag Fill Valve**

The bibag fill valve opens as needed to add water to the bibag disposable during dialysis. When bibag is not used for bicarbonate during dialysis, this valve will remain closed. In rinse and cleaning modes, this valve will alternate with valve 103.

## **101 – bibag Vent Valve**

The bibag vent valve opens momentarily during dialysis when air is detected in the bibag air separation chamber. When bibag is not used for bicarbonate during dialysis (jug mode), this valve will open momentarily when air is detected in the bibag air separation chamber.

## **103 – Hydrochamber Outlet Valve**

The hydrochamber outlet valve opens in dialysis when valve 100 is closed. In rinse and cleaning modes, this valve will alternate with valve 100.

## **104 – Bicarbonate Port Valve**

Closed for bibag dialysis. Opens to empty the bibag disposable and during bibag startup. Opens when sodium bicarbonate concentrate is supplied. When sodium bicarbonate is supplied by a pressurized supply, this valve will open and close based on pressure at pressure transducer 110.

## **105 – Acid Port Valve**

Used to regulate the pressure to the acid pump. Will open and closed based upon pressure at pressure transducer 106.

## **106 – Acid Port Pressure Transducer**

Senses pressure of the acid concentrate supply. Pressure detected from this sensor is used in conjunction with valve 105 to regulate the pressure to the acid concentrate pump.

## **108 – Rinse Port Valve**

This valve is electrically in parallel with valve 104. It opens and closes at the same time as valve 104.

## **110 - bibag Pressure Transducer**

The bibag pressure transducer is used to measure the pressure inside the bibag disposable. Also used to measure the pressure of the sodium bicarbonate concentrate source when bibag is not used.

## **111 – bibag Air Separation Chamber**

The bibag air separation chamber separates air from the sodium bicarbonate concentrate upon leaving the bibag disposable. It also is used to separate air from the sodium bicarbonate concentrate supplied by external sources (pre-mixed concentrates).

## **112 – bibag Air Separation Chamber Air Sensor**

The bibag air separation chamber air sensor detects air in the air separation chamber.

## **113 – bibag Conductivity Cell**

The bibag conductivity cell is used to measure the conductivity of the sodium bicarbonate concentrate leaving the bibag disposable and the conductivity of the pre-mixed concentrates.

## Hydraulic Component Descriptions (cont.)

### **114 – bibag Temperature Thermistor**

The bibag temperature thermistor is used to measure the temperature of the bicarbonate concentrate leaving the bibag disposable and the pre-mixed concentrate.

### **115 – bibag Present Switch**

The bibag present switch is built into the bibag connector. The switch is positioned so that when a bibag disposable is attached to the bibag connector the switch is pressed indicating the presence of a bibag disposable.

### **116 – Bicarbonate Temperature Thermister**

Used with conductivity cell 117 to measure conductivity.

### **117 – Bicarbonate Conductivity Cell**

Measures conductivity of the bicarbonate concentrate from the bibag disposable after it is mixed with R.O. water.

### **118 – bibag Filter**

Removes any particles that may enter through the bibag disposable.

### **bibag Connector**

The bibag connector holds the bag with dry bicarbonate during dialysis. The bibag connector incorporates a three position door (see Figure 3). The door may be placed in the position open, operating, or bypass. In the open position (1) and (4), a bibag disposable may be installed or removed from the connector. The operating position (5) is used when a bibag disposable is installed for dialysis. The bypass position (3) is the completely closed position (not possible if a bag is hanging from the connector). The door must be in the closed position (3) for rinse, cleaning, and jug dialysis mode. Position (2) should not be used.

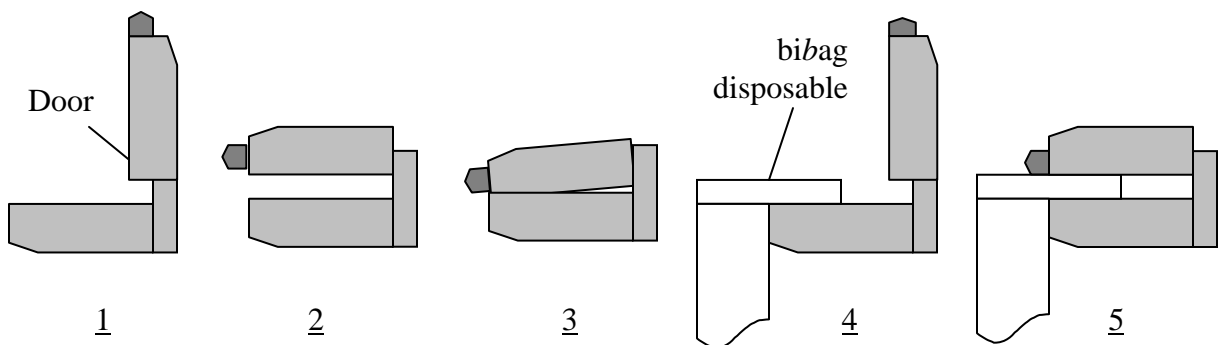

Figure 3



# Hydraulic Operation

## Dialysis with *bi*bag

Heated water from chamber E of the hydrochamber flows to the junction of valves 100 and 103. Valve 100 opens and the *bi*bag disposable will start filling when the dialysate temperature at temperature sensor 3 reaches 30 degrees C. Valve 100 will close when the pressure reaches 150mmHg as monitored by the pressure transducer 110. After this initial fill, valves 104 and 108 open, valve 103 closes, the balancing chamber valves open and any excess gas generated in the bag is flushed through the hydraulics down the drain. The flow pump runs and the machine is kept in bypass during this initial flush. Afterwards, additional water will be added to the bag to maintain pressure in the bag of about 90mmHg.

The conductivity cell (113) and temperature sensor (114) measure the conductivity and temperature of the sodium bicarbonate concentrate as it leaves the bag. The temperature compensated conductivity determines the concentration of the sodium bicarbonate concentrate and the delivery rate of the bicarbonate pump (17).

If air is sensed by the probes (112) in the air separation chamber, valve 101 is momentarily opened to vent the air.

If the pressure in the *bi*bag disposable does not change while the bicarbonate pump is pumping, an airlock condition is detected. To remove the airlocked condition in the bicarbonate pump, valve 100 opens to pressurize the bag to 150mmHg. Next, the flow is stopped, the balance chamber valves are opened up, the flow pump runs, and the machine is kept in bypass.

Conductivity cell 117 checks the amount of sodium bicarbonate added to the dialysate and a conductivity alarm will be displayed if the solution is not within  $\pm 5\%$  of expected.

## Dialysis with Sodium Bicarbonate Concentrates

Jug bicarbonate dialysis is also supported with the *bi*bag hydraulics. To run in this mode, the *bi*bag connector door must be completely closed and the bicarbonate connector pulled out. Valves 104 and 108 will open and close based on pressure transducer 110 to allow bicarbonate concentrate to reach the bicarbonate pump. Conductivity and temperature of the solution is monitored.

## Rinse & Mandatory Rinse

Mandatory rinse is run after a chemical disinfect. Both rinse and mandatory rinse are the same valve sequence for the valves in the *bi*bag hydraulics. Valves 104 and 108 alternate opening every 3 seconds. Valves 100 and 103 alternate opening every 3 seconds. Valve 101 is also opened periodically when conductivity is low. Valve 105 is open.



# Electronic Description

## bibag Interface Board

The *bibag* interface board ‘piggybacks’ onto the actuator - test board and communicates with it. The *bibag* hydraulic assembly and the *bibag* distribution box 2 connect electrically to the *bibag* interface board with ribbon cables.

The *bibag* interface board contains all of the electronics required to activate the 5 additional valves, read conductivity from the *bibag* and bicarbonate conductivity cells, read temperature from the *bibag* and bicarbonate temperature thermistor, read the status of the *bibag* air sensor, and read the status of the *bibag* door’s internal switches. A microcontroller on the board controls all of these processes and communicates serially with the actuator - test board. The presence of the communications between the *bibag* interface board and the actuator - test board indicates to the system the presence of the *bibag* hydraulic components.

The *bibag* pressure transducer is automatically calibrated when the door is open, and the value is saved into memory on the *bibag* interface board.

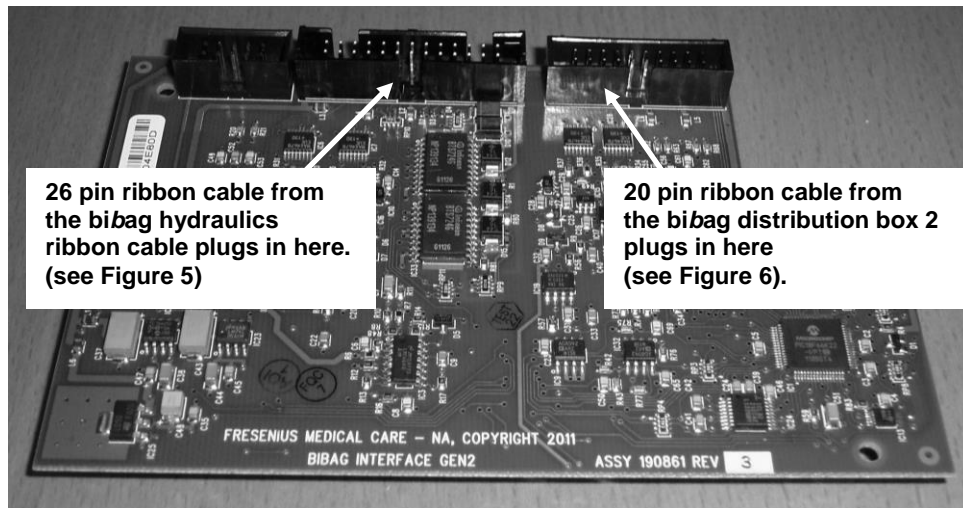

**Figure 4 – *bibag* Interface Board**

### **biBag Hydraulic Assembly – Distribution Board**

The biBag hydraulic assembly - distribution board is a passive board that connects to the biBag interface board through a 26 pin cable. All of the individual biBag components on the biBag hydraulic assembly connect electrically to this distribution board.

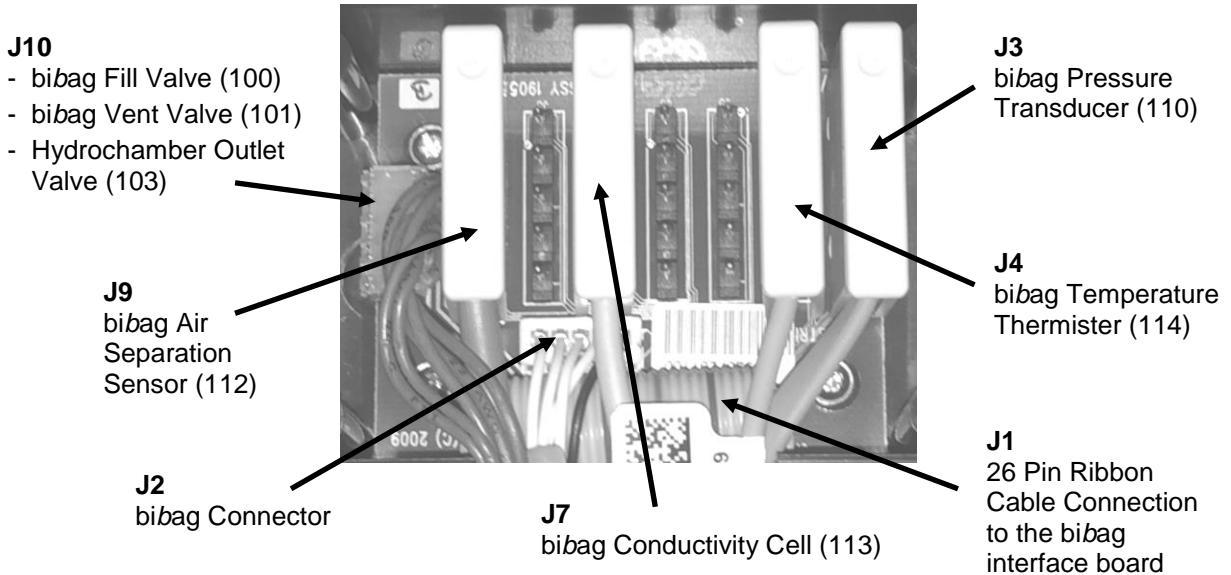

**Figure 5 – biBag hydraulic Assembly – Distribution Board**

### **biBag Distribution Box 2 – Distribution Board**

The biBag distribution box 2 - distribution board is a passive board that connects to the biBag interface board through a 20 pin cable. All of the individual biBag components on the distribution box 2 connect electrically to this distribution board.

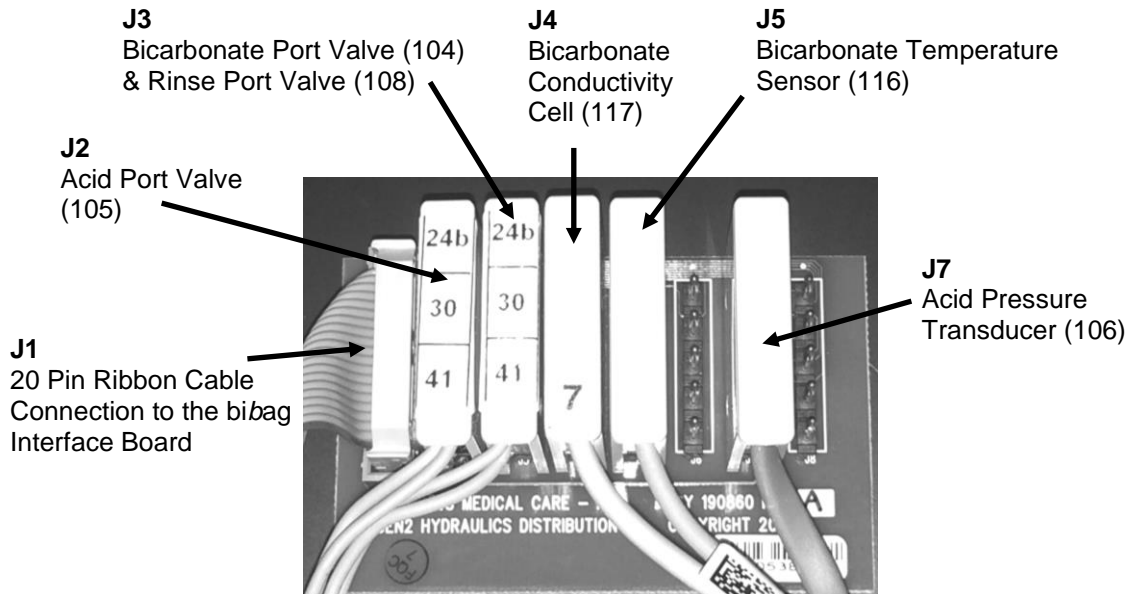

**Figure 6 - biBag Distribution Box 2 – Distribution Board**

# Electronic Block Diagram

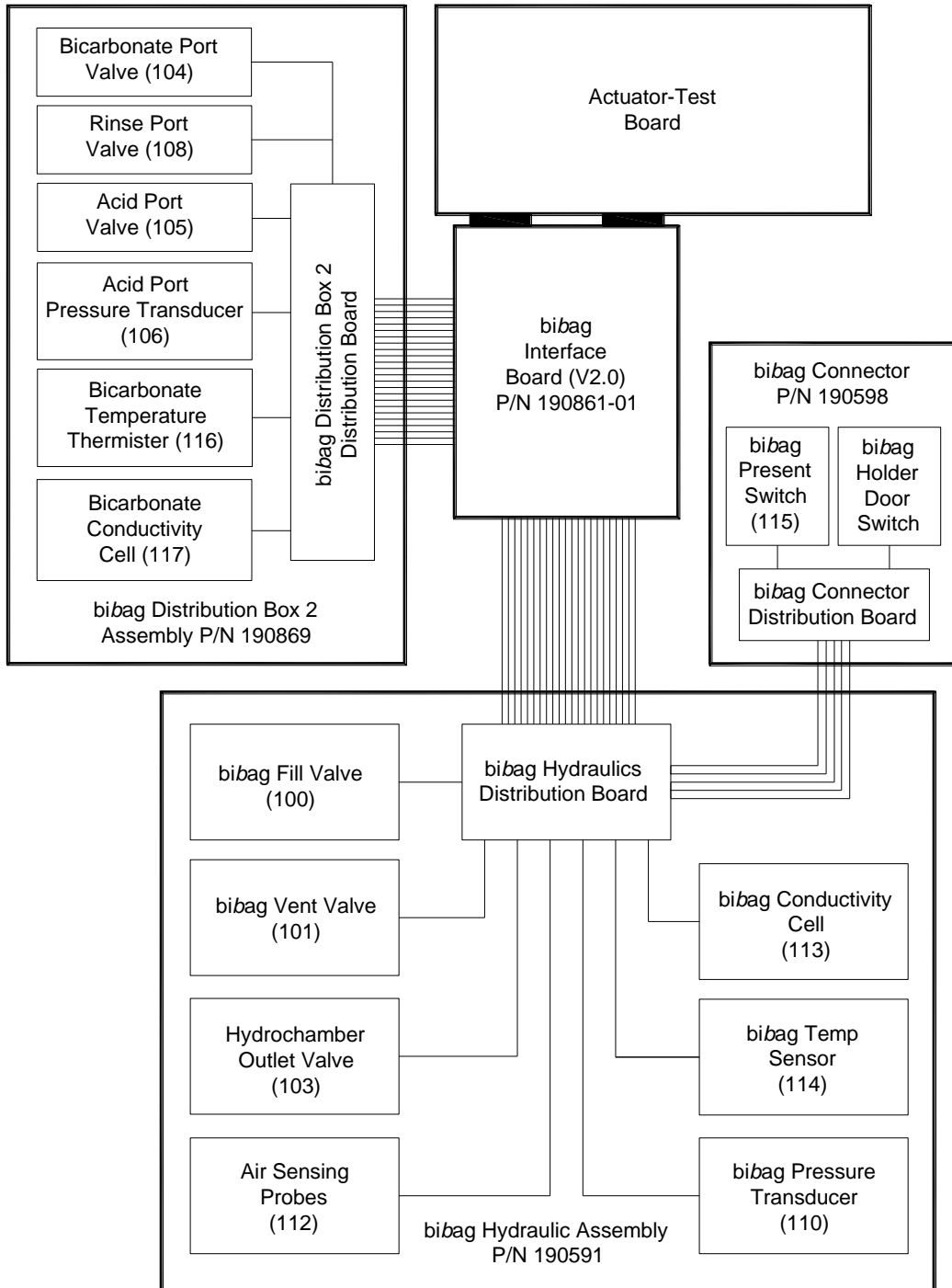

**Figure 7**

# Calibrations

## Pressure Transducers

Power the machine on and enter Service Mode.

From the Calibrate Sensors screen, select the Pressure Transducers screen button.

On the Pressure Transducers screen, select the Regulator Pressure screen button.

1. Pull the Acid and Bicarbonate connectors and insert them halfway back into their ports.
2. Press the [Confirm] key to set the 0 (zero) pressure calibration. The screen will change.  
When prompted, press the [Confirm] key to save the calibration. The screen will change.  
Press the [Confirm] key again to finish the calibration process.

## Bicarbonate Conductivity Cell

### Required Tools:

Mesa 90XL Dialysate Meter With Conductivity/Temperature Module	Mesa Serial Cable (P/N 368402-10)	Null Modem (P/N 190323)
--	--------------------------------------	----------------------------

### Required Supplies:

- Liquid bicarbonate
- Machine must be connected to an R.O. water source for this calibration.

Power the machine on and enter Service Mode.

From the Calibrate Sensors screen, select the Cond Cells screen button.

On the Cond Cells screen, select Bicarb Cell screen button.

1. Using the Null Modem, connect the Mesa Serial Cable between the 90XL Dialysate Meter and the RS232 port on the rear of the card cage. Refer to Figure 8 for connection assistance.

**Note:** A No Comm To 90XL message will occur if the internal cable for the RS232 port is not connected to P6 on the Functional board (see Figure 8).

2. Connect the Dialysate Lines to the 90XL Conductivity/Temperature Module.
3. Connect the acid connector to a container of R.O. water and the bicarbonate connector to a container of sodium bicarbonate concentrate.
4. Press the [Confirm] key to start the calibration.

The screen will change and the screen will display Calibration In Progress...

During the calibration process, the 90XL will communicate with the machine through the RS232 port.

When the calibration process is complete, the screen will display Bicarb Cond Cell calibration is complete.

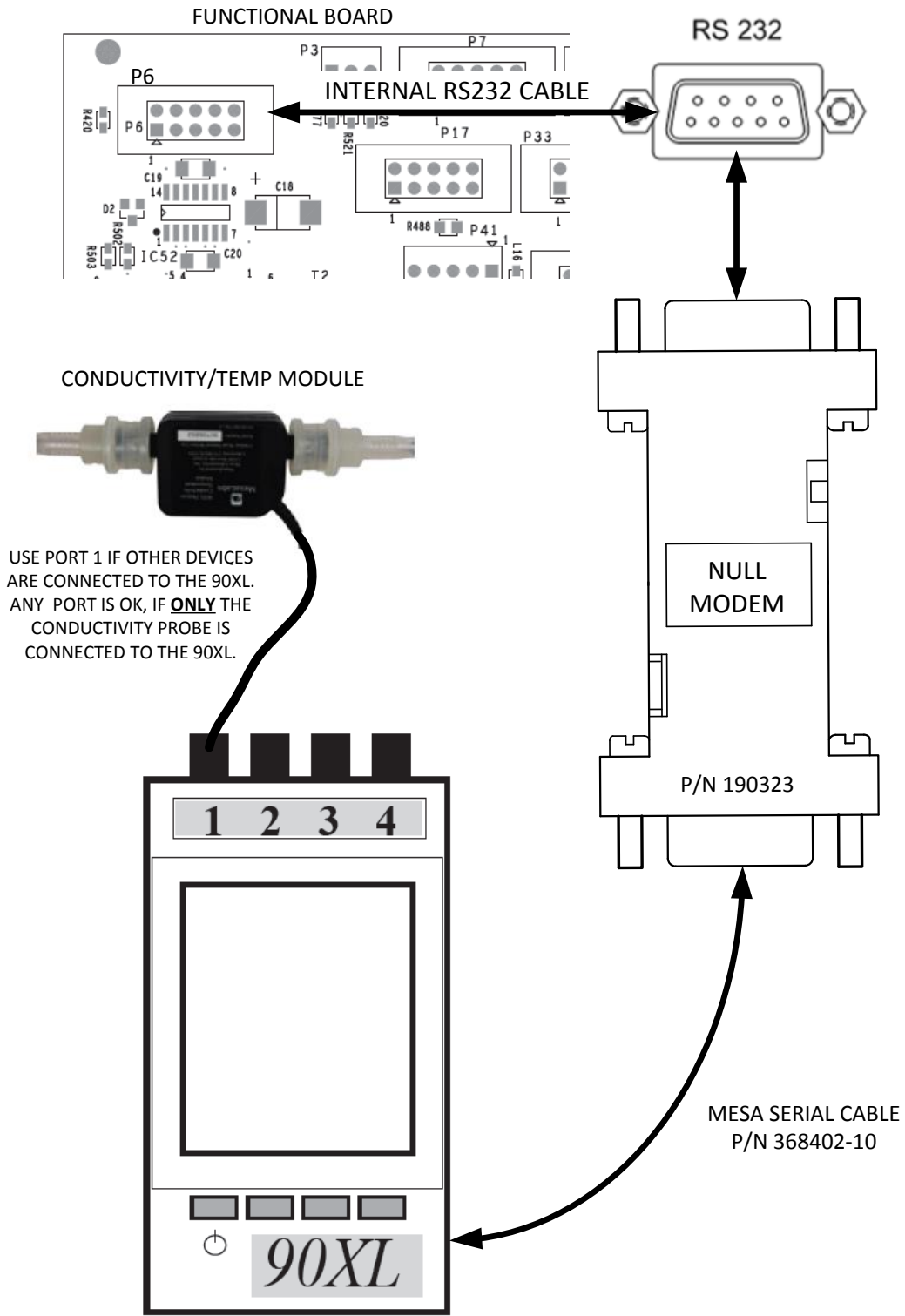

**Figure 8 – Null Modem Connection to the 90XL**

## Annual Maintenance

Annual *bi*bag maintenance consists of the following:

- Perform *bi*bag Inlet Filter Replacement.
- Perform *bi*bag Connector Maintenance.
- Perform the *bi*bag Pressure Transducers calibration. (see page 12)

### *bi*bag Inlet Filter Replacement

Annually replace the filter (P/N M30225) in tubing assembly labeled 1 connected between the *bi*bag connector and the *bi*bag air separator.

Note the direction of the flow arrow on the filter housing

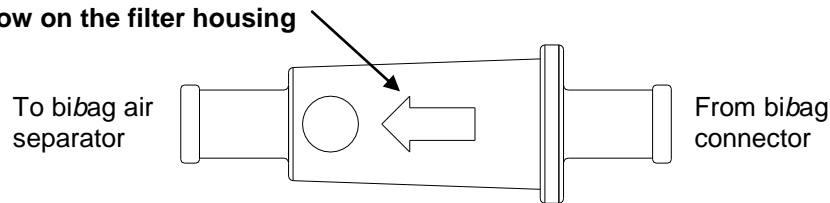

Figure 9 – *bi*bag Inlet Filter (M30225)

### *bi*bag Connector Maintenance

Annually replace the two (2) o-rings (P/N 640919) on the *bi*bag connector door.

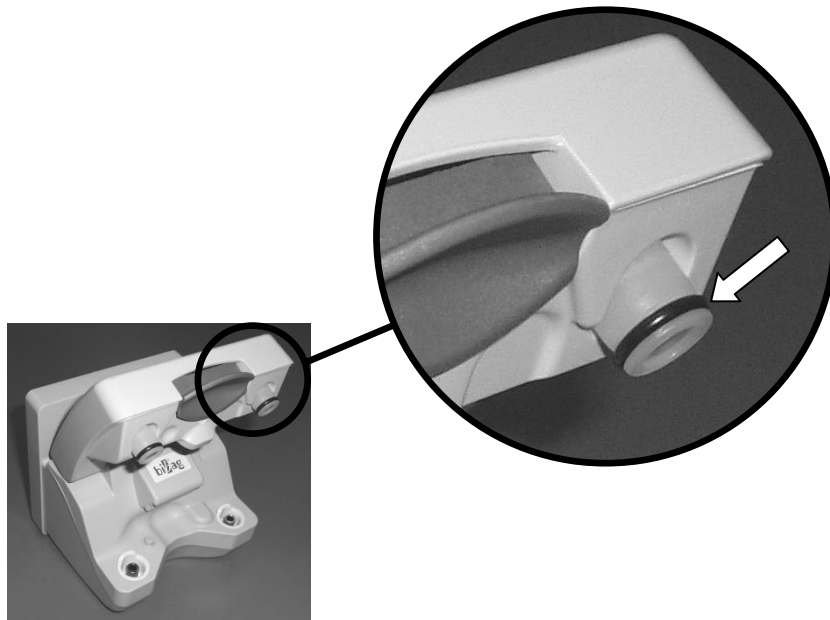
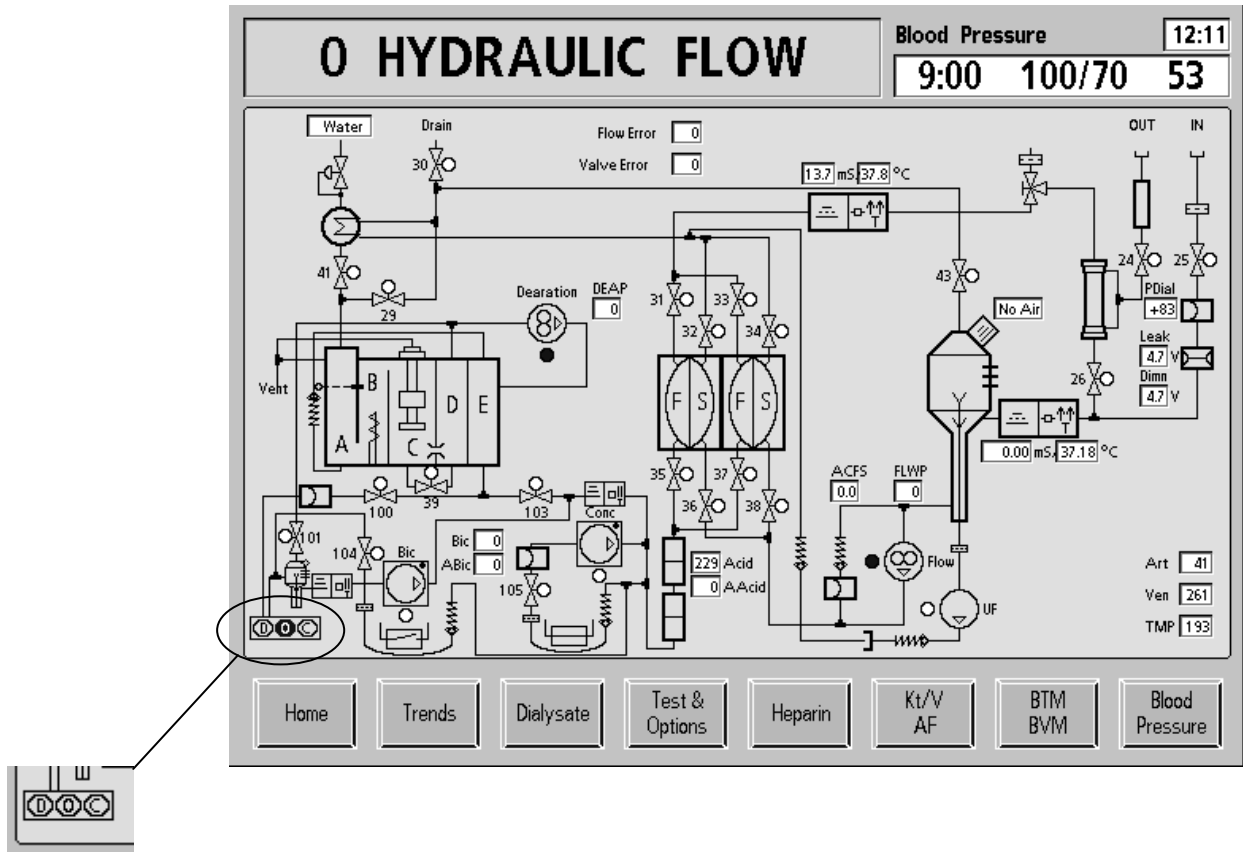

Figure 10– *bi*bag Connector Door O-Rings (640919)



# Debug Screens

## Debug Screen 0 – HYDRAULIC FLOW - bibag portion



**D**  
The bibag connector is in the correct state for dialysis (i.e., it is in the Operating state).

**O**  
The bibag connector is open (i.e., it is in the Open No bibag disposable, Partially Closed No bibag disposable, or Open with bibag disposable present).

**C**  
The bibag connector is closed (i.e., it is in the Bypass state).

## **Debug Screens (cont.)**

*Debug Screen 0 – HYDRAULIC FLOW - bibag portion (cont.)*

### **100**

This displays the status of the bibag fill valve. The valve opens as needed to add water to the bibag disposable during dialysis. When bibag is not used for bicarbonate during dialysis, this valve will remain closed. In rinse and cleaning modes, this valve will alternate with valve 103. The indicator turns blue when the valve is open.

### **101**

This displays the status of the bibag vent valve. The valve opens during bibag dialysis when air is detected in the bibag air separation chamber. When bibag is not used for bicarbonate during dialysis (jug mode), this valve will open when air is detected in the bibag air separation chamber. The indicator turns blue when the valve is open.

### **103**

This displays the status of the hydrochamber outlet valve. The valve opens in dialysis when valve 100 is closed. In rinse and cleaning modes, this valve will alternate with valve 100. The indicator turns blue when the valve is open.

### **104**

This displays the status of the bicarbonate port valve. Closed for bibag dialysis. Opens to empty the bibag disposable and during bibag startup. Opens when sodium bicarbonate concentrate is supplied. When sodium bicarbonate is supplied by a pressurized supply, this valve will open and close based on pressure at pressure transducer 110.

### **105**

This displays the status of the acid port valve. Used to regulate the pressure to the acid pump. Will open and closed based upon pressure at pressure transducer 106

## Debug Screens (cont.)

### Debug Screen 14 – bibag

Note: Debug Screen 15 on 2008K@home™

14 bibag							Blood Pressure		
							9:12		
							9:00	100/70	53
Opn None	Operating	Bypass	Cls None	Opn Bag	Bag On		D bd Ver		
<input type="text" value="0"/>	<input type="text" value="0"/>	<input type="text" value="0"/>	<input type="text" value="0"/>	<input type="text" value="0"/>	<input type="text" value="0"/>		<input type="text" value=""/>		
Init State	Tx State	End State	Vent	DeAirLock	Tm Bypass	Post Flush	Fill		
<input type="text" value="0"/>	<input type="text" value="0"/>	<input type="text" value="0"/>	<input type="text" value="0"/>	<input type="text" value="0"/>	<input type="text" value="0"/>	<input type="text" value="0"/>	<input type="text" value="0"/>		
Bic Pump	Bypass Ctl	V43 Ctl	TMP Ctl	Air	Vent En	Empty	Emptied		
<input type="text" value="0"/>	<input type="text" value="0"/>	<input type="text" value="0"/>	<input type="text" value="0"/>	<input type="text" value="0"/>	<input type="text" value="0"/>	<input type="text" value="0"/>	<input type="text" value="0"/>		
No Comm	12V Err	5V Err	-5V Err	I2C Err	Door Err		Cond Cal		
<input type="text" value="0"/>	<input type="text" value="0"/>	<input type="text" value="0"/>	<input type="text" value="0"/>	<input type="text" value="0"/>	<input type="text" value="0"/>		<input type="text" value="0"/>		
Temp Cal	Pres Cal	Empty Long	Vent Long	Bag Leak	Pres Snr	Pres Hi	Pres Low		
<input type="text" value="0"/>	<input type="text" value="0"/>	<input type="text" value="0"/>	<input type="text" value="0"/>	<input type="text" value="0"/>	<input type="text" value="0"/>	<input type="text" value="0"/>	<input type="text" value="0"/>		
Val Comm	Val1 Err	Val2 Err	Cond High	Cond Low	Cond Senr	Temp Senr	Bic Lock		
<input type="text" value="0"/>	<input type="text" value="0"/>	<input type="text" value="0"/>	<input type="text" value="0"/>	<input type="text" value="0"/>	<input type="text" value="0"/>	<input type="text" value="0"/>	<input type="text" value="0"/>		
Temperature	Conductivity	Pressure	Concentration	JCon Low	JCon Hi	JConLowLmt	JConHiLmt		
<input type="text" value="0.00"/>	<input type="text" value="0.00"/>	<input type="text" value="0"/>	<input type="text" value="0.00"/>	<input type="text" value="0"/>	<input type="text" value="0"/>	<input type="text" value="0.00"/>	<input type="text" value="0.00"/>		
Home	Trends	Dialysate	Test & Options	Heparin	Kt/V AF	Crit-Line	Blood Pressure		

### Open None

No bibag disposable on bibag connector, bibag door fully open.

1 =Yes / 0 = No

### Operating

bibag disposable on bibag connector, bibag door in bibag dialysis position.

1 =Yes / 0 = No

### Bypass

No bibag disposable on bibag connector, bibag door fully closed.

1 =Yes / 0 = No

### Cls None

No bibag disposable on bibag connector, bibag door partially closed.

1 =Yes / 0 = No

## **Debug Screens (cont.)**

*Debug Screen 14 (15) – bibag (cont.)*

### **Opn Bag**

bibag disposable on connector, bibag door fully open.

1 =Yes / 0 = No

### **Bag On**

bibag disposable on bibag connector.

1 =Yes / 0 = No

### **D bd Ver**

bibag interface board (daughter board) software version.

### **Init State**

System is in the bibag Initial state.

1 =Yes / 0 = No

### **Tx State**

System is in the bibag Treatment state.

1 =Yes / 0 = No

### **End State**

System is in the bibag End state.

1 =Yes / 0 = No

### **Vent**

System is running the bibag vent process.

1 =Yes / 0 = No

### **DeAirLock**

System is running the bibag deairlock (air lock removal) process.

1 =Yes / 0 = No

### **Tm Bypass**

System is running the bibag timed bypass process.

1 =Yes / 0 = No

### **Post Flush**

System is running the bibag post empty flush process.

1 =Yes / 0 = No

## **Debug Screens (cont.)**

*Debug Screen 14 (15) – bibag (cont.)*

### **Fill**

System is running the bibag fill process (Initial state).

1 = Yes / 0 = No

### **Bic Pump**

System requests the bicarbonate pump to be on for a bibag process.

1 = Yes / 0 = No

### **Bypass Ctl**

System requests bypass of the dialyzer for a bibag process.

1 = Yes / 0 = No

### **V43 Ctl**

System is suppressing the “Valve 43 Failure” error for a bibag process.

1 = Yes / 0 = No

### **TMP Ctl**

System requests TMP control, which isolates the dialyzer and freezes dialysate pressure for a bibag process.

1 = Yes / 0 = No

### **Vent En**

System indicates that it is enabled to do the bibag vent process.

1 = Yes / 0 = No

### **Air**

Air is detected by the bibag air separation chamber air sensor.

1 = Yes / 0 = No

### **Empty**

System is running the bibag empty process.

1 = Yes / 0 = No

### **Emptied**

System indicates that the bag is emptied.

1 = Yes / 0 = No

## **Debug Screens (cont.)**

*Debug Screen 14 (15) – bibag (cont.)*

### **No Comm**

Indicates a bibag No Communication error.

1 =Yes / 0 = No

### **12V Err**

Indicates a bibag +12 V error.

1 =Yes / 0 = No

### **5V Err**

Indicates a bibag +5 V error.

1 =Yes / 0 = No

### **-5V Err**

Indicates a bibag -5 V error.

1 =Yes / 0 = No

### **I2C Err**

Indicates a bibag I<sup>2</sup>C error.

1 =Yes / 0 = No

### **Door Err**

Indicates a bibag Door error.

1 =Yes / 0 = No

### **Cond Cal**

Indicates a bibag Conductivity Calibration error.

1 =Yes / 0 = No

### **Temp Cal**

Indicates a bibag Temperature Calibration error.

1 =Yes / 0 = No

## **Debug Screens (cont.)**

*Debug Screen 14 (15) – bibag (cont.)*

### **Pres Cal**

Indicates a bibag Pressure Calibration error.

1 =Yes / 0 = No

### **Empty Long**

Indicates a bibag Emptying Too Long error.

1 =Yes / 0 = No

### **Vent Long**

Indicates a bibag Venting Too Long error.

1 =Yes / 0 = No

### **Bag Leak**

Indicates a bibag disposable Leak error.

1 =Yes / 0 = No

### **Pres Snr**

Indicates a bibag Pressure Sensor error.

1 =Yes / 0 = No

### **Pres Hi**

Indicates a bibag disposable Pressure Too High error.

1 =Yes / 0 = No

### **Pres Low**

Indicates a bibag disposable Pressure Too Low error.

1 =Yes / 0 = No

### **Val Comm**

Indicates a bibag Valve Communication error.

1 =Yes / 0 = No

### **Val1 Err**

Indicates a bibag Valve 1 error.

1 =Yes / 0 = No

## Debug Screens (cont.)

*Debug Screen 14 (15) – bibag (cont.)*

### **Val2 Err**

Indicates a bibag Valve 2 error.

1 =Yes / 0 = No

### **Cond High**

Indicates a bibag Conductivity High error.

1 =Yes / 0 = No

### **Cond Low**

Indicates a bibag Conductivity Low error.

1 =Yes / 0 = No

### **Cond Senr**

Indicates a bibag Conductivity Sensor error. This bit is only set in the Rinse program.

1 =Yes / 0 = No

### **Temp Senr**

Indicates a bibag Temperature Sensor error. This bit is only set in the Rinse program.

1 =Yes / 0 = No

### **Bic Lock**

Indicates a bibag Bicarbonate Pump Air Locked error.

1 =Yes / 0 = No

### **Temperature**

Displays the temperature in °C of the sodium bicarbonate concentrate from either the bibag disposable or a jug.

### **Conductivity**

Displays the conductivity in mS/cm of the sodium bicarbonate concentrate from either the bibag disposable or a jug. This value is temperature compensated.

### **Pressure**

Displays the bibag disposable pressure in mmHg.

### **Concentration**

Displays the concentration in g/L of the bibag disposable during bibag dialysis.



## **Debug Screens (cont.)**

*Debug Screen 14 (15) – bibag (cont.)*

### **JCon Low**

Indicates a bicarbonate (jug) conductivity low error.

1 = Yes / 0 = No

### **JCon Hi**

Indicates a bicarbonate (jug) conductivity high error.

1 = Yes / 0 = No

### **JConLowLmt**

Displays the bicarbonate (jug) conductivity lower limit in mS/cm.

### **JConHiLmt**

Displays the bicarbonate (jug) conductivity higher limit in mS/cm.

## Debug Screens (cont.)

Debug Screen 15 – Bic Mon & Act. Reg

Note: Debug Screen 16 on 2008K@home™

15 Bic Mon & Act. Reg					Blood Pressure	13:48
					9:00	100/70 53
Bic Low	Bic Hi	Bic Cell Cond	Bic Mon temp	RO Cond		
0	0	0	0	0		
TCB	Bic Lo Th	Bic Mon Cond	Bic Hi Th	Bic Slope	Bic Offset	
0	0	0	0	0.00	-1	
Acid Press	Bic Press	Inlet W temp	PHT Err	AcidPr Cal Er	InletT Cal Er	
0	0	0.00	0	0	0	
bicT Cal Er	V105 Er	V104 Er	Reg O/S Rx	V105 Er 0		
0	0	0	0	0		
V105 Er C	V104 Er 0	V104 Er C	Acid PresOff	Bic PresOff		
0	0	0	0	0		

Home Trends Dialysate Test & Options Heparin Kt/V AF BTM BVM Blood Pressure

### Bic Low

This bit is normally set to 0, and is set to 1 when the bicarbonate conductivity (Bic Mon Cond) has been less than “Bic Lo Th” for 40 balance chamber switches.

### Bic Hi

This bit is normally set to 0, and is set to 1 when the bicarbonate conductivity (Bic Mon Cond) has been greater than “Bic Hi Th” for 40 balance chamber switches.

### Bic Cell Cond

The raw uncompensated bicarbonate conductivity being seen at the Bicarbonate Conductivity Cell 117.

### Bic Mon temp

The temperature being seen at the Bicarbonate Temperature Thermistor 116.

## **Debug Screens (cont.)**

*Debug Screen 15 (16) – Bic Mon & Act. Reg (cont.)*

### **RO Cond**

The RO water conductivity value measured at the end of rinse used to compensate “Bic Cell Cond”.

### **TCB**

Theoretical Conductivity of Bicarbonate based on the machines Base Na+ and Bicarbonate settings.

### **Bic Lo Th**

The lower threshold for compensated bicarbonate conductivity (Bic Mon Cond), 5% below TCB.

### **Bic Mon Cond**

The compensated bicarbonate conductivity based on Bic Cell Cond, Bic Mon temp, Bic Slope, Bic Offset, and RO Cond.

### **Bic Hi Th**

The upper threshold for compensated bicarbonate conductivity (Bic Mon Cond), 5% above TCB.

### **Bic Slope**

The slope value of the bicarbonate conductivity calculated from the bicarbonate conductivity cell calibration.

### **Bic Offset**

The offset value of the bicarbonate conductivity calculated from the bicarbonate conductivity cell calibration.

### **Acid Press**

The compensated pressure seen at the Acid Port Pressure Transducer 106.

### **Bic Press**

The compensated pressure seen by the bibag Pressure Transducer 110 (bibag machine) or the bicarbonate Pressure Transducer 107 (non-bibag machine).

**Inlet W temp** – (Not used)

## **Debug Screens (cont.)**

*Debug Screen 15 (16) – Bic Mon & Act. Reg (cont.)*

### **PHT Err**

Indicates a bibag Pressure Holding Test failure.

1 =Yes / 0 = No

### **AcidPr Cal Er**

Indicates an Acid Pressure Calibration Error.

1 =Yes / 0 = No

### **InletT Cal Er** – (Not Used)

### **BicT Cal Er**

Indicates a Bicarb Temperature Calibration Error.

1 =Yes / 0 = No

### **V105 Er**

Indicates a Valve 105 Error.

1 =Yes / 0 = No

### **V104 Er**

Indicates a Valve 104 or Valve 108 Error.

1 =Yes / 0 = No

### **Reg O/S Rx**

Indicates the bibag interface board has received the Regulator Pressure service mode calibration data.

1 = Data Received / 0 = Data not Received.

### **V105 Er O**

Indicates Valve 105 is Stuck Open.

1 =Yes / 0 = No

### **V105 Er C**

Indicates Valve 105 is Stuck Closed.

1 =Yes / 0 = No

## **Debug Screens (cont.)**

*Debug Screen 15 (16) – Bic Mon & Act. Reg (cont.)*

### **V104 Er O**

Indicates Valve 104 or Valve 108 is Stuck Open.

1 =Yes / 0 = No

### **V104 Er C**

Indicates Valve 104 or Valve 108 is Stuck Closed.

1 =Yes / 0 = No

### **Acid PresOff**

The compensation value for Acid Port Pressure Transducer 106 based on the Regulator Pressure service mode calibration.

### **Bic PresOff**

The compensation value for bibag Pressure Transducer 110 (bibag machine) based on the Regulator Pressure service mode calibration.

# Troubleshooting

## Error messages

All status messages are displayed on the control panel screen. These messages are generated due to conditions and events that occur in the machine during operation. These messages will reset when the condition causing the message is corrected. In some cases, the operator must reset them.

A list of *bibag* related messages can be found in the

*2008<sup>®</sup>T Hemodialysis Machine bibag*  
*Operator's Manual P/N 508213.*

*2008K@home<sup>™</sup> Hemodialysis Machine bibag*  
*Operator's Manual P/N 508340.*

The list includes:

- The *bibag* related Message
- Meaning of the Message
- Action Required

A full list of machine messages may be found in the

*2008<sup>®</sup>T Hemodialysis Machine Operator's Manual P/N 490122*

*2008K@home<sup>™</sup> Hemodialysis Machine Operator's Manual P/N 490180*

## Spare Parts

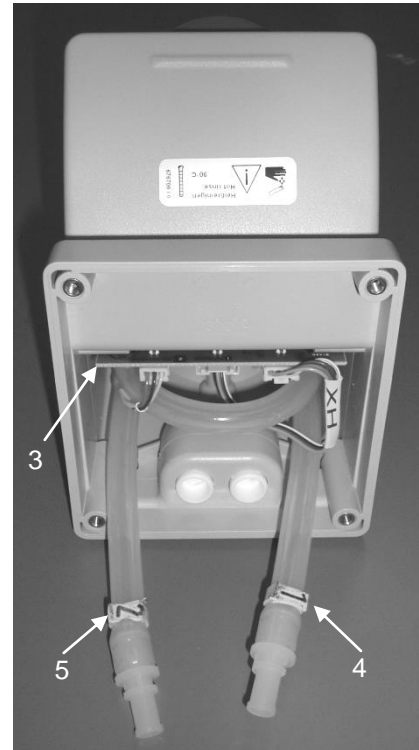
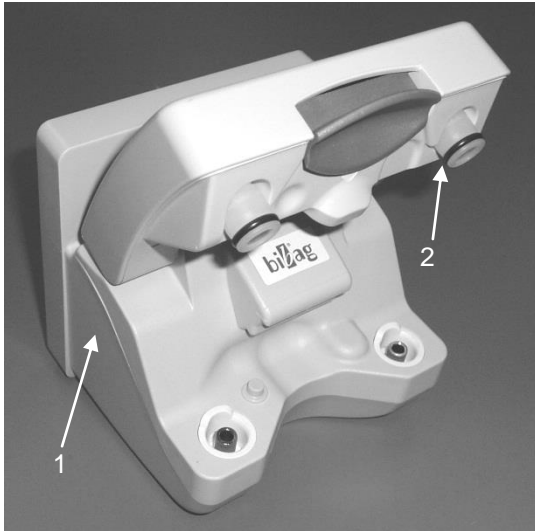

Item #	Description	Part Number
1.	biBag connector complete	190598
2.	biBag connector o-ring	640919
3.	biBag connector circuit board	190547
4.	Tubing label "1"	M56202
5.	Tubing label "2"	M56203

## Spare Parts (cont.)

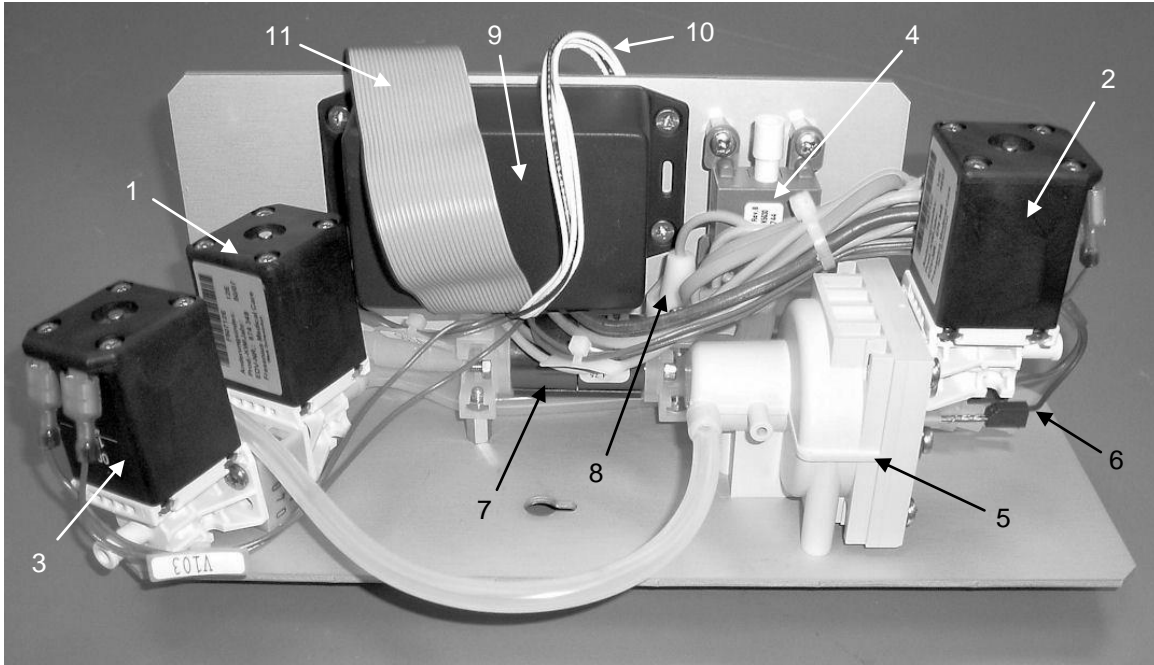

Item #	Description	Part Number
	<b>biBag Hydraulic assembly</b> Includes all shown components including items 1 through 12.	190591
1.	biBag Fill Valve (V100)	642951
2.	biBag Vent Valve (V101)	674349
3.	Hydrochamber Outlet Valve (V103)	642951
4.	biBag Pressure Transducer (110)	190140
5.	biBag Air Separation Chamber (111) with V101 and Air Sensor Probes; item 6 not included	190673
6.	biBag Air Separation Chamber Air Sensor Probe Cable	668033
7.	biBag Conductivity Cell (113)	M39797
8.	biBag Temperature Thermistor (114)	676502
9.	biBag Distribution board (inside box)	190526
10.	Cable - biBag distribution board to biBag connector	190525
11.	Cable - biBag distribution board to biBag interface board	190670
12.	Assembly, biBag distribution Includes items 9 and 11	190669



## Spare Parts (cont.)

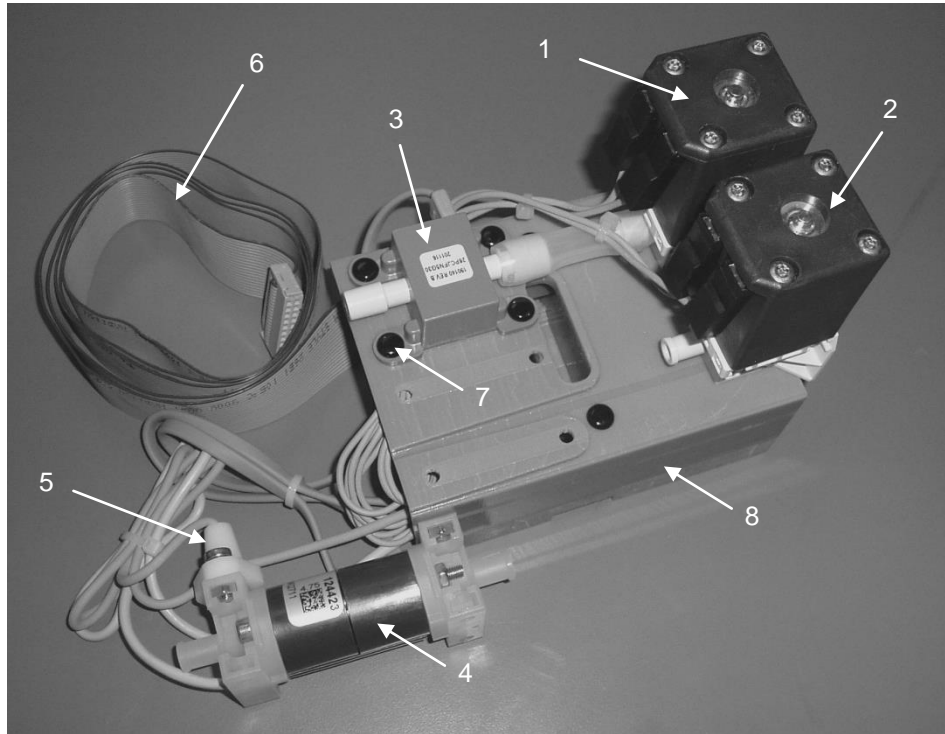

Item #	Description	Part Number
	Distribution Box 2 assembly Includes all shown components including items 1 through 10.	190869
1.	Acid Port Valve (V105)	643418
2.	Bicarbonate Port Valve (V104)	643418
3.	Acid Port Pressure Transducer (106)	190140
4.	bi <i>bag</i> Conductivity Cell (117)	M39797
5.	bi <i>bag</i> Temperature Thermistor (116)	676502
6.	Cable - bi <i>bag</i> Distribution Box 2 to bi <i>bag</i> interface board	190865
7.	Retaining Pin	330801-03
8.	Distribution Box 2 only	290684
9.	Distribution Box 2 cover Item not shown – cover inside item 8 and is used to retain item 10.	290685
10.	Distribution Box 2 circuit board Item not shown – board inside item 8	190860

## Spare Parts (cont.)

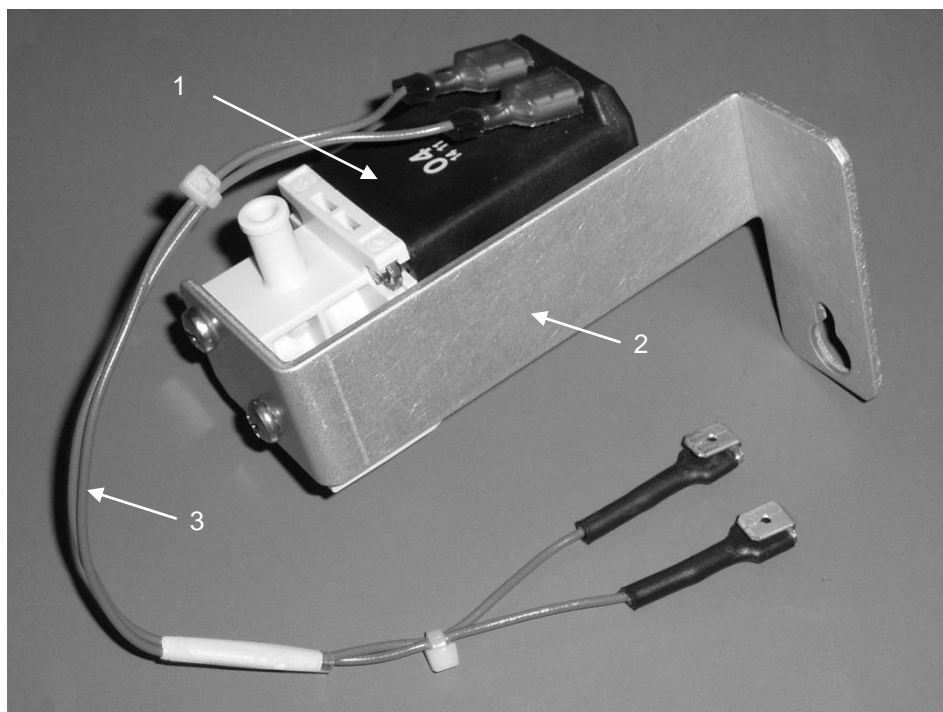

<u>Item #</u>	<u>Description</u>	<u>Part Number</u>
	Valve 108 Assembly Includes all shown components including items 1 through 3.	190959
1.	Valve 108	643418
2.	Bracket, Valve Single Mount	290767
3.	biBag Valve 108 Cable Assembly	190958

## Spare Parts (cont.)

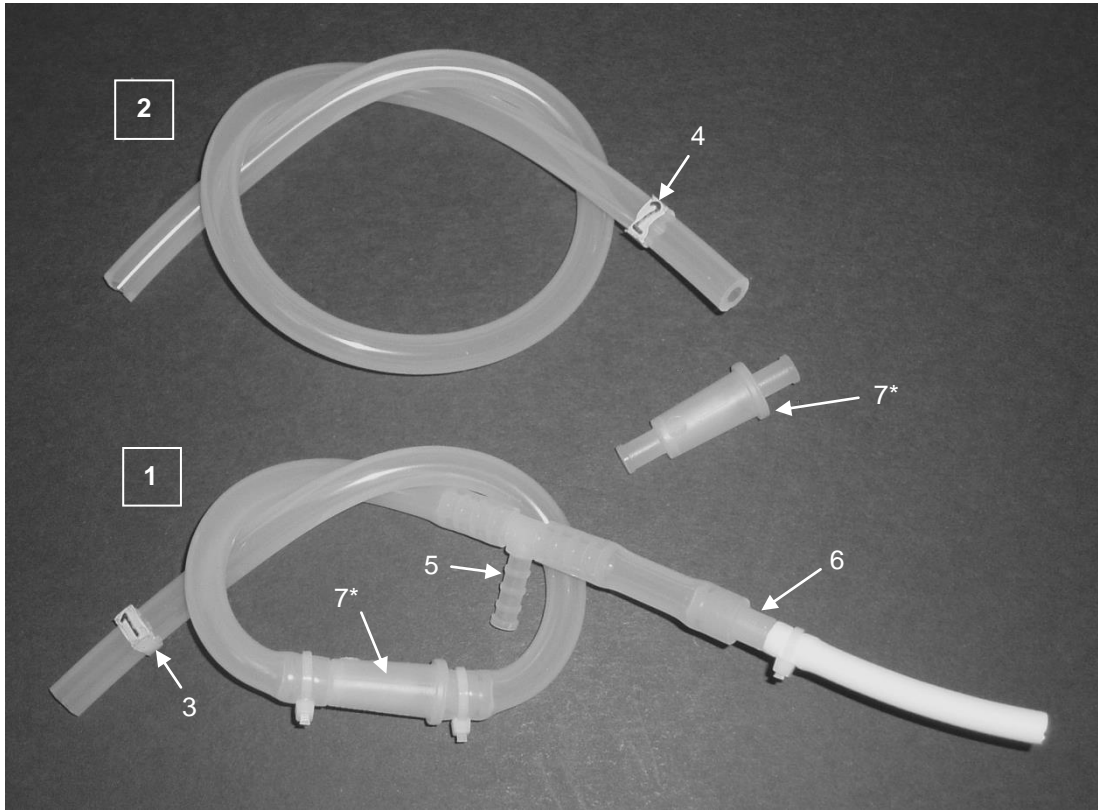

Item #	Description	Part Number
1.	Tubing 21.5" Assembly labeled 1	190877
2.	Tubing 19" labeled 2	190602
3.	Tubing label "1"	M56202
4.	Tubing label "2"	M56203
5.	Tee Connector, 3/16	674648
6.	Reducer Fitting	M38033
7.	bi <i>bag</i> Inlet Filter*	M30225

**\*Note:** When replacing item 7 (bi*bag* Inlet Filter), reference the arrow on the housing for proper directional flow. Correct flow is from the bi*bag* connector to the bi*bag* air separator.

## Spare Parts (cont.)

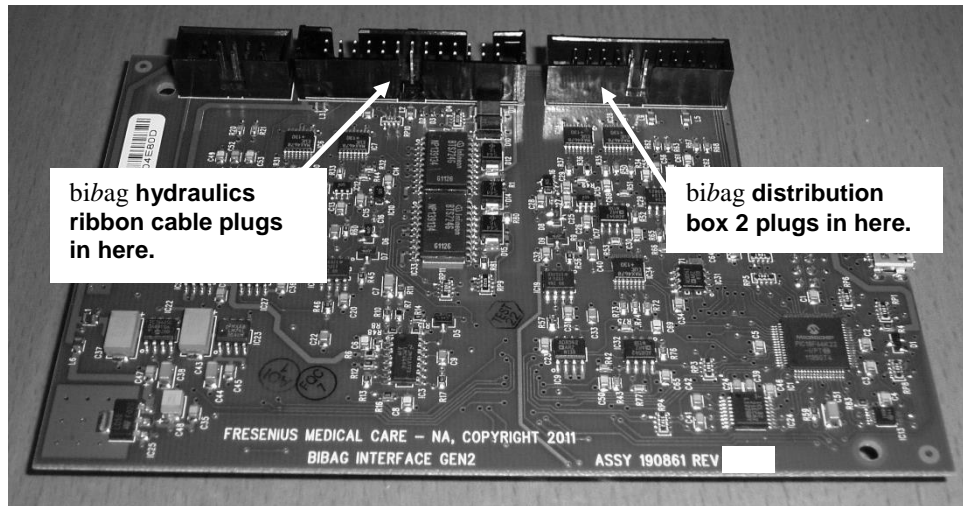

Item #	Description	Part Number
1.	bibag Interface Board with software	190861-01

The following items are not illustrated

2	bibag V2.0 Technician's Manual	490188
3	2008T bibag Operator's Instructions	508213
4	2008T bibag Installation Kit	190872
5	2008T bibag V2.0 Upgrade Kit	190873
6	2008K@home bibag Operator's Instructions	508340
7	2008K@home bibag Installation Kit	190883
8	2008K@home bibag V2.0 Upgrade Kit	190884







**Fresenius Medical Care North America**

Manufactured by:  
Fresenius USA, Inc.  
4040 Nelson Avenue  
Concord, CA 94520  
800 227-2572

<http://www.fmcna.com>